

NeutraDens surface drainage system for draining liquids hazardous to water over slopes in LAU systems

With general technical approval Z-74.3-140

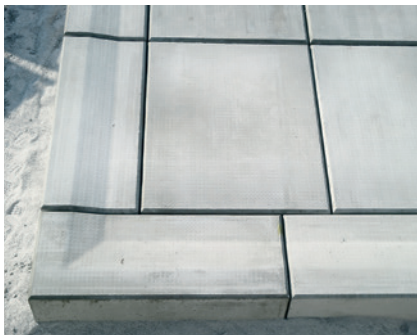

Wherever water and soil can be contaminated by wastewater containing mineral oil and chemical pollutants, there are strict building regulations. The ground must be safely sealed and, depending on the application area, retention systems such as separating plants or containment areas must be installed downstream.

Complete solutions for protecting water and soil

The NeutraDens surface drainage system provides economic, concrete- and process-optimised complete solutions for a wide variety of problematic cases for protecting water and soil.

For example, it enables liquid-impermeable roadway and/or drainage surfaces to be produced in accordance with the guidelines of the German Reinforced Concrete Committee. As a modular system, NeutraDens can be used to assemble large slab systems including the necessary water guidance systems and drainage facilities. The various system elements are manufactured using quality-controlled, precast concrete components and can be walked on after installation and driven over with pneumatic-tyred road vehicles up to a maximum of SLW 60 in accordance with DIN 1072.

Advantages at a glance

- + Consistent quality due to factory production, especially with regard to strength, dimensional accuracy, structure and evenness
- + Elements can be installed irrespective of the weather
- + Short construction time
- + Short commissioning time: The grouted concrete elements can be driven on after two days.
- + Elements can be reused when making modifications or after repair work; repairs are visually undetectable after replacing elements.

Complete overview of the available NeutraDens components

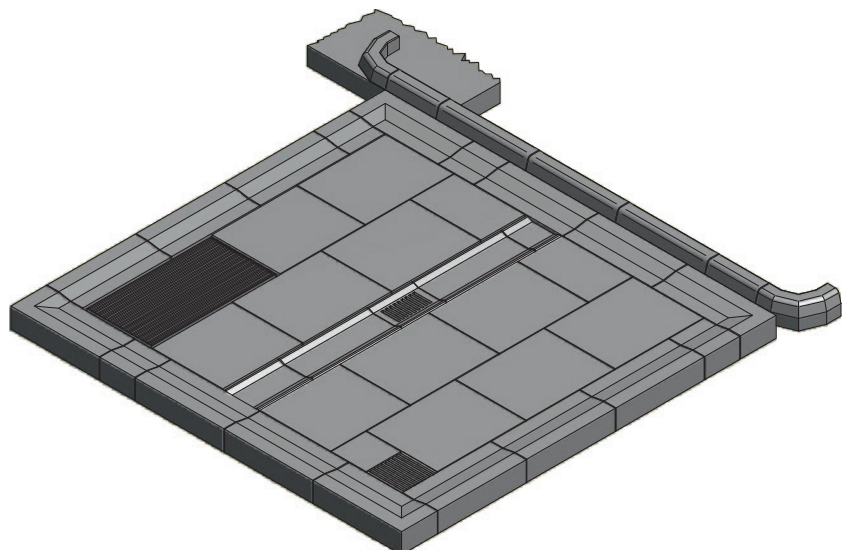

Optimised and coordinated – Surface drainage system with separating plant or retention device

Webcode M5592 

Filling and washing areas

The safe solution that combines liquid-tight concrete elements for sealing surfaces and their drainage with Mall's proven separation technology – for public and private tank facilities, washing and cleaning areas.

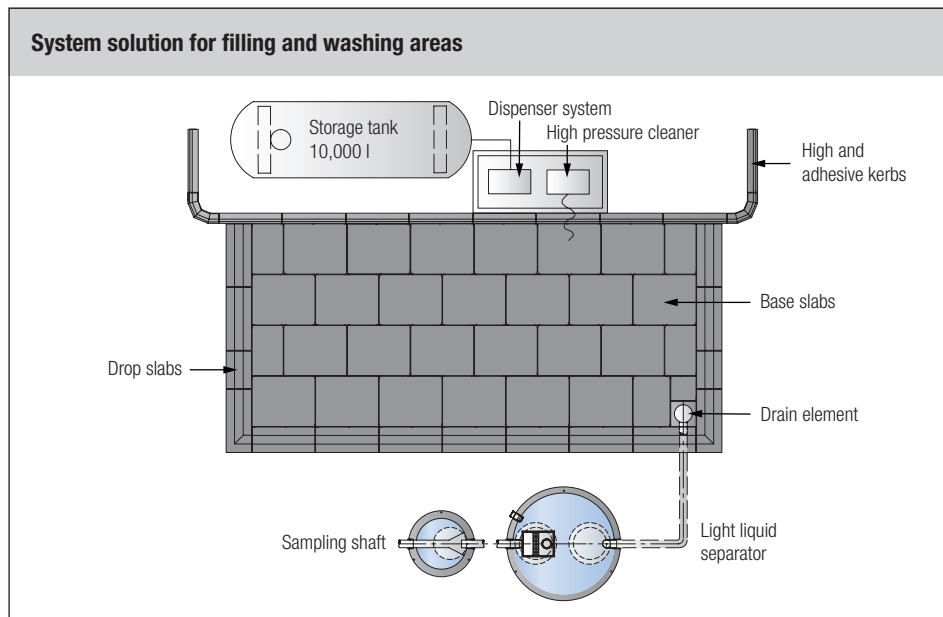

Filling area

The effective solution for areas at plants for producing, treating and using substances harmful to waterways as well as storage, filling and handling facilities in the chemical and petrochemical industries, at filling stations and in other industry sectors.

